

MACHINING TOLERANCES	
0.0	±0.1"
0.00	±0.01"
0.000	±0.005"
UNLESS NOTED OTHERWISE	

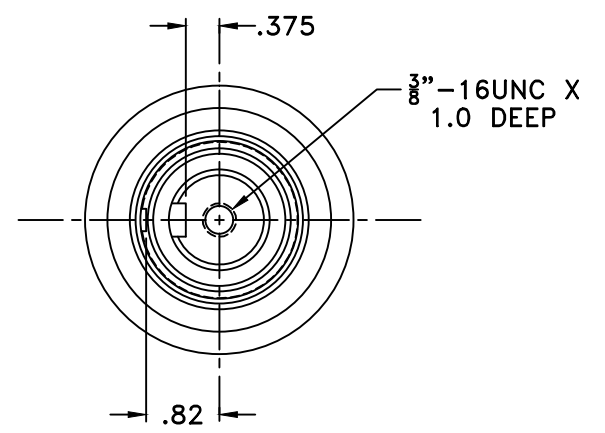
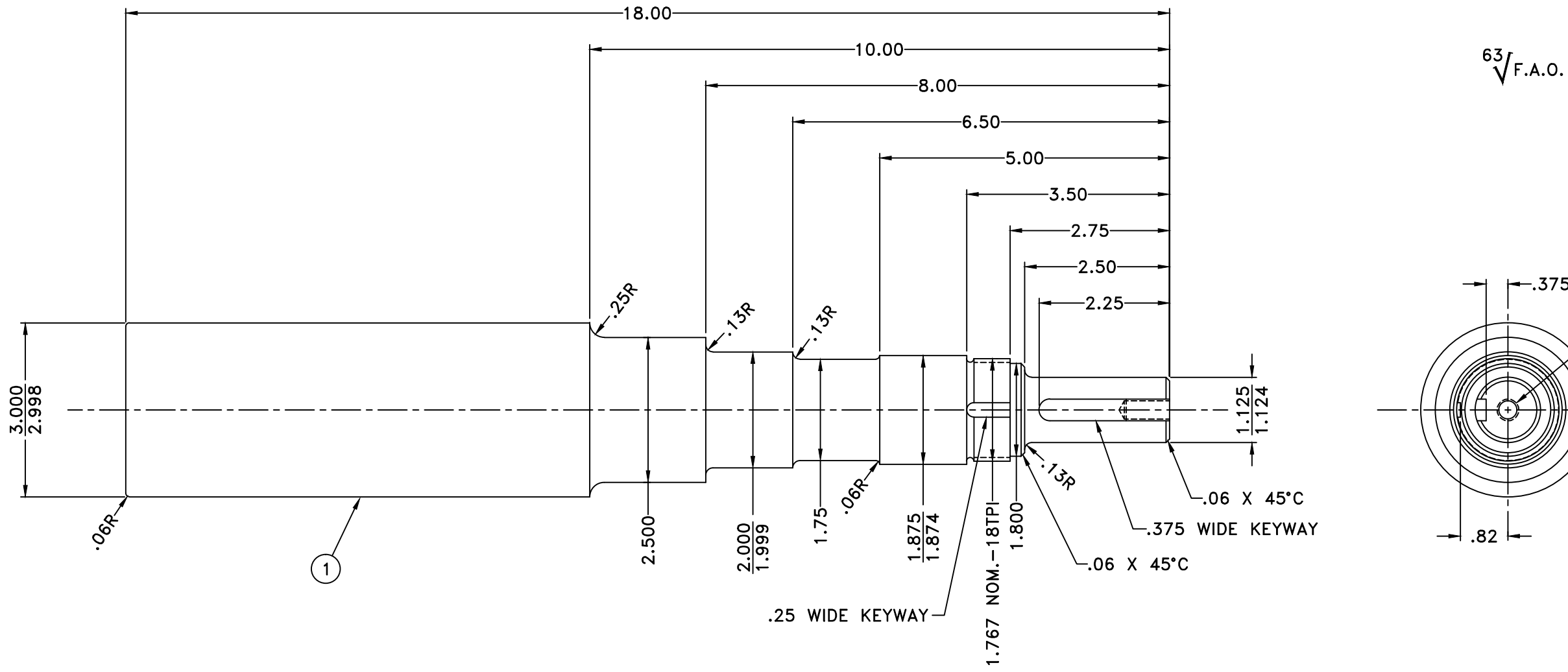

ITEM	REQ'D	DESCRIPTION	MATERIAL	DIMENSIONS
1	1	JOURNAL	4340 HR	ø3.125 ROUND

	TITLE: ROLL JOURNAL	
	CUSTOMER: YOUR NAME HERE	
	DATE: 7-30-13	SCALE: 1=2
	JOB: 13XX	RWB-001 0
SHEET: 1 OF 1		